

BOEING WANTS IN ON THE SOLAR AIRPLANE CRAZE

News / Manufacturer

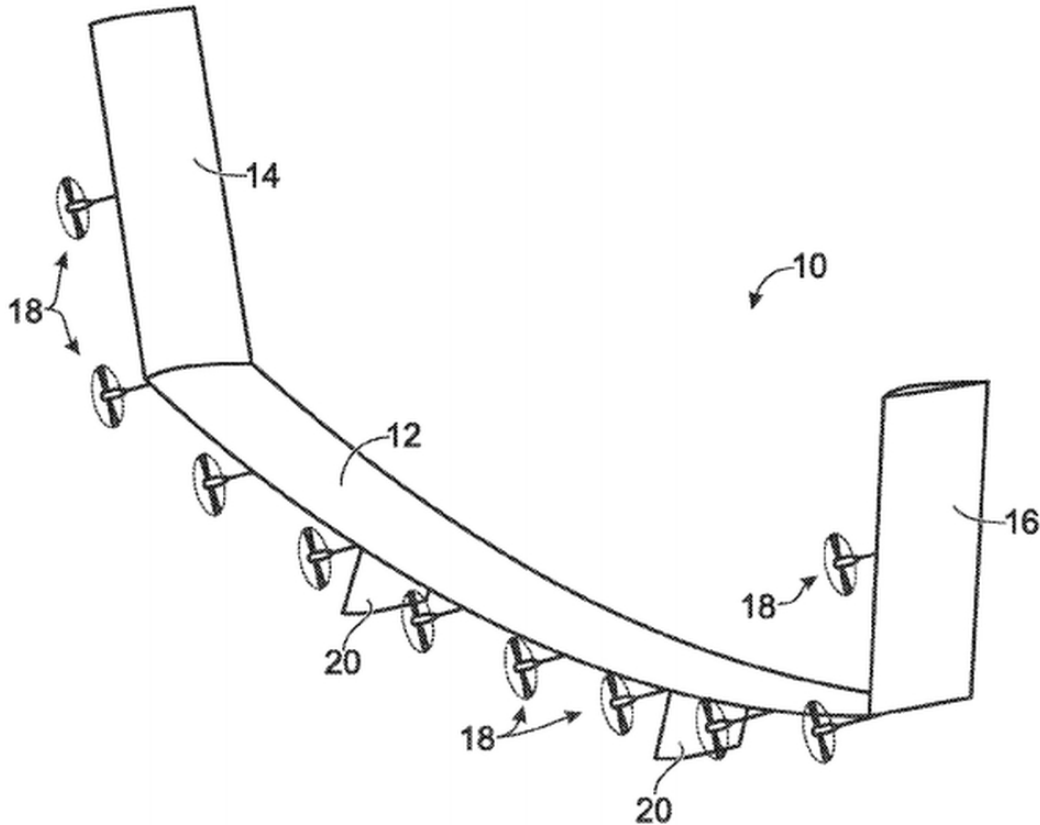

Boeing filed a patent application in recent weeks simply titled "Solar Powered Airplane," which proposes a wing-shaped drone with enormous winglets on either end completely covered in solar panels. The idea would be to make a drone capable of staying at high altitudes for long periods of time, similar to projects that are currently being undertaken at Facebook and Google.

Why would Boeing want in on Silicon Valley's turf? Well, there's the obvious part — Boeing is an aviation company — but there's also the fact that high-altitude, solar-powered drones may be able to take the place of satellites for certain services like long-distance communications. As a prolific commercial satellite builder, it stands to reason that Boeing would want to make sure that it's not losing business in the process.

Solar aircraft require substantial surface area simply to generate enough electrical power to stay aloft, often giving them an unusual appearance that looks very little like the aircraft that we're accustomed to. Solar Impulse 2, a gangly, manned solar aircraft currently traveling around the world, just landed in New York City.

13 JUNE 2016

ARTICLE LINK:

<https://to.50skyshades.com/news/manufacturer/boeing-wants-in-on-the-solar-airplane-craze>