

# LUFTHANSA TECHNIK PHILIPPINES COMPLETES ITS FIRST TWELVE-YEAR CHECK ON AN A380

News / Maintenance / Trainings

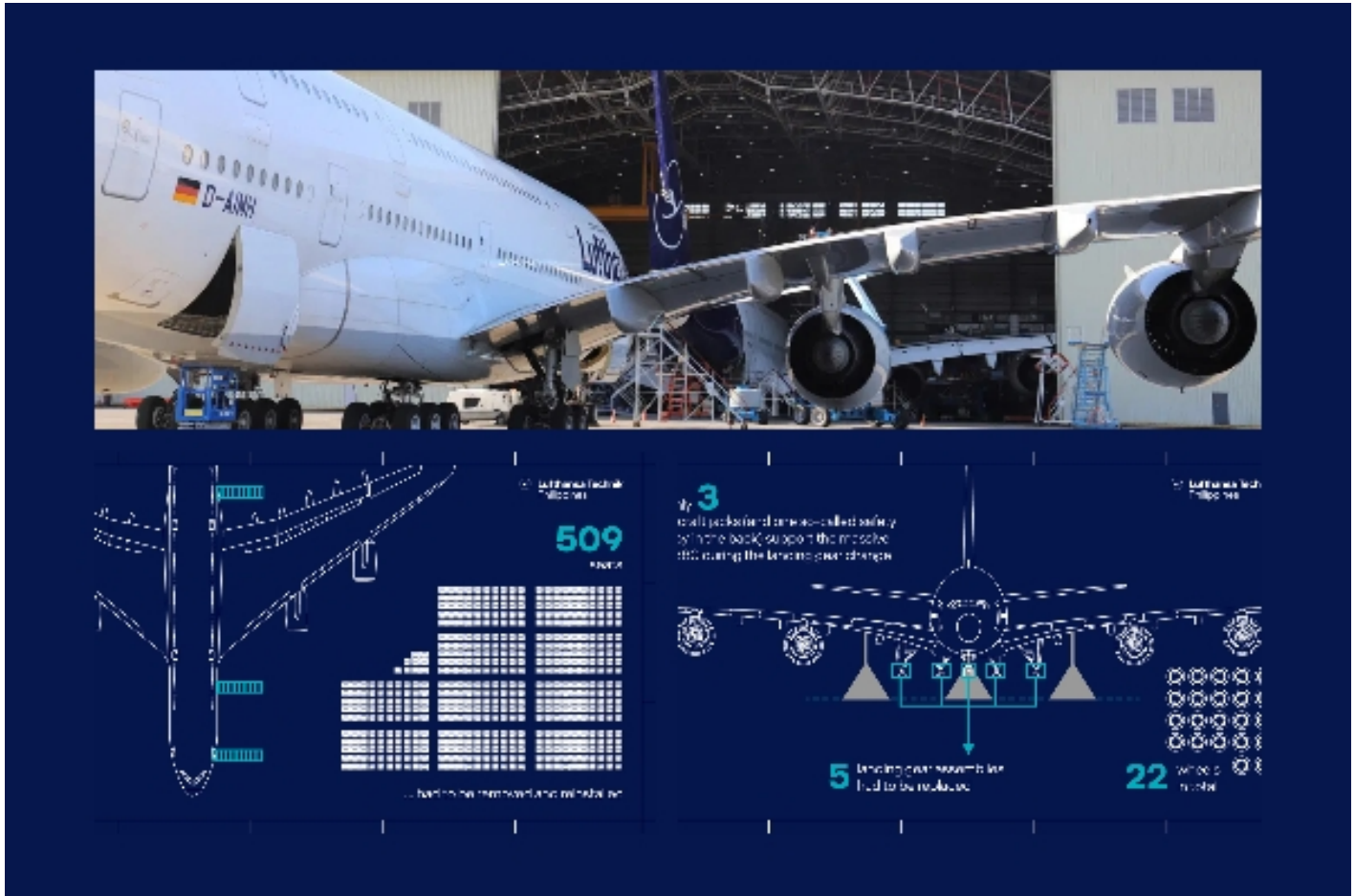

**For the first time in its history, Lufthansa Technik Philippines has completed the so-called twelve-year check on an Airbus A380, supporting the return of the world's largest passenger aircraft to the fleet of Lufthansa Airlines. After successfully completing the most extensive work package in its maintenance schedule last week, the A380 registered D-AIMC has returned to Germany.**

Elmar Lutter, Chief Executive Officer of Lufthansa Technik Philippines, commented: “The return of the A380 to the fleets of many airlines has also boosted demand for maintenance services enormously. We are benefiting quite well from this with our A380 expertise here in Manila, that we recently even expanded with the third overhaul line. In view of the delays in the delivery of numerous new wide-body aircraft, I am certain that services for the A380 will remain an integral part of our portfolio for years to come.”

Compared to the less extensive three- or six-year checks that Lufthansa Airlines’ first four reactivated Airbus A380s also underwent at LTP, the scheduled twelve-year check involves much more intensive inspections of the aircraft structure. In order to provide adequate access thereto,

more than 500 passenger seats and all other monuments from the two passenger decks had to be removed and later reinstalled during the layover of “Mike Charlie” in Manila. Various large aircraft components were also completely replaced or temporarily dismantled as part of the check.

### ***Complete replacement of all landing gear assemblies***

One of the milestones of every twelve-year check is the complete replacement of the landing gear, which on the Airbus A380 consists of five individual gear assemblies with a total of 22 wheels. After a dozen years, these highly stressed components, which have to absorb a maximum take-off weight of up to 560 tons on a fully loaded A380, have reached the end of their scheduled service life. To make sure that this not also marks the end of the components' overall lifespan, the experts at Lufthansa Technik Landing Gear Services in London are overhauling the four main landing gear components to almost new condition, while the nose landing gear is overhauled by its manufacturer.

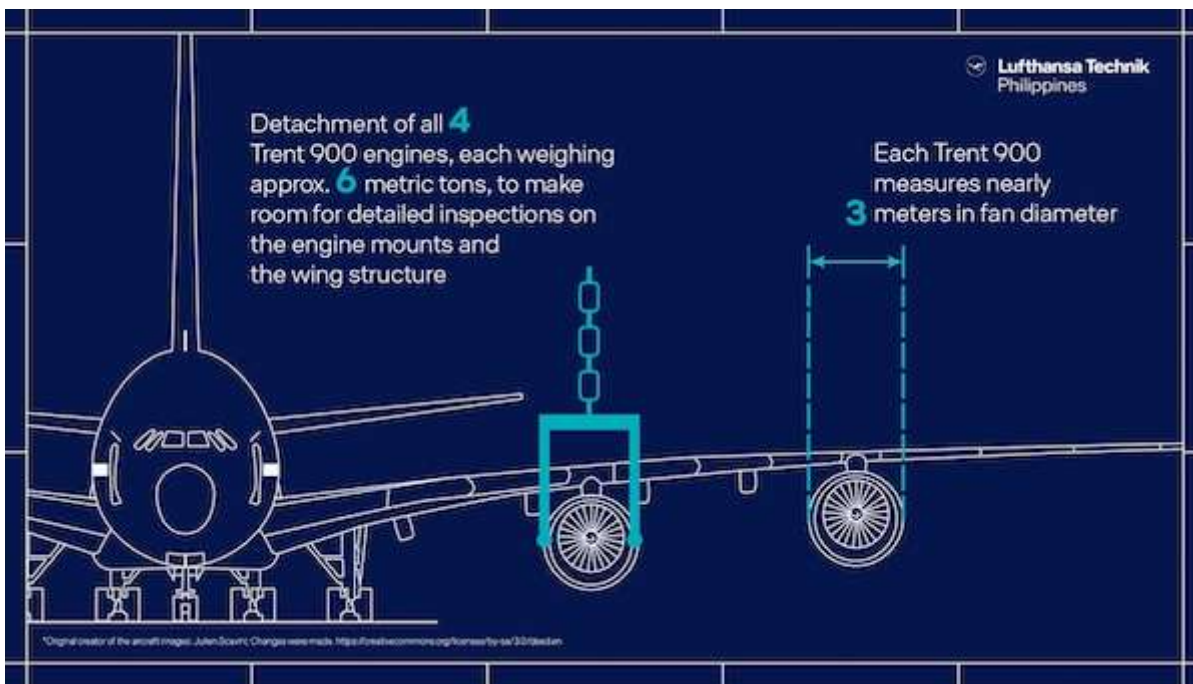

### ***Engines make way for detailed inspections***

No less spectacular is the removal of all four Rolls-Royce Trent 900 engines from the wings of the A380. These will be temporarily removed as part of the twelve-year check to allow the experts to carry out more detailed structural inspections of the wings and engine mounts. The engines themselves, with a diameter of around three meters at the air intake and a dry weight of more than six metric tons, will only undergo minor inspections in line with their remaining service life. In addition to the scheduled work packages of a twelve-year check, the LTP team also had to carry out modifications, such as implementing all airworthiness directives (ADs) issued by the manufacturer Airbus during the long inactivity of the aircraft.

### ***Full house in Manila: Overhaul layovers for A380s in demand like never before***

At peak times, more than 100 aircraft mechanics were working on D-AIMC as part of the twelve-year check. Despite its more than 42,000 flying hours and over 4,300 flight cycles, “Mike Charlie” is now almost ready for its return to active scheduled service with Lufthansa Airlines, but also fit for the time until its next, but then significantly smaller, base maintenance check. With D-AIMH “Mike Hotel”, which was transferred from Frankfurt to Manila on February 11, the next twelve-year check

on an A380 is already underway at LTP.

In general, such overhauls, known as base maintenance in technical jargon, are still in high demand for the world's largest passenger aircraft. Numerous airlines have now put the aircraft type, which still enjoys high popularity among passengers, back into service in order to cope with the extreme increase in demand for air travel since the end of the pandemic. In addition to Lufthansa Airlines, LTP currently counts four other A380 operators among its customer base. Despite the opening of a third overhaul line for the type last year, the company's capacities will therefore be almost fully utilized well into the coming years.

20 FEBRUARY 2024

**ARTICLE LINK:**

<https://to.50skyshades.com/news/maintenance-trainings/lufthansa-technik-philippines-completes-its-first-twelve-year-check-on-an-a380>